

AREA OF DEMISED SPACE TAKEN FROM OUTSIDE FACE OF EXTERIOR WALLS, ESTIMATED CENTERLINE OF DEMISING WALLS, AND OUTSIDE FACE OF COMMON WALLS.

- A1:**
- CEILING HEIGHT = 14'-6"
 - FRONTAGE = 45'-10"
 - DEPTH = 37'-4"
 - # OF ENTRANCES = 1 SET OF DOUBLE DOORS
 - GREASE TRAP = 1
 - VENT CHASE = 5'-7 3/4" x 2'-11 1/4"
 - OUTDOOR SPACE = 230 SF

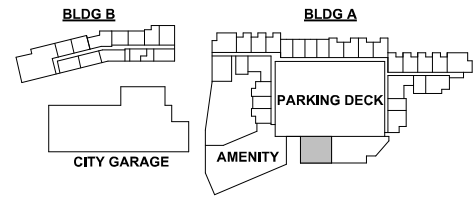

RETAIL A1 PLAN
 3/32" = 1'-0"
 220045 | 08.18.2023
 © 2022 Cline Design Associates, PA. This graphic is for illustrative purposes only and is subject to change.

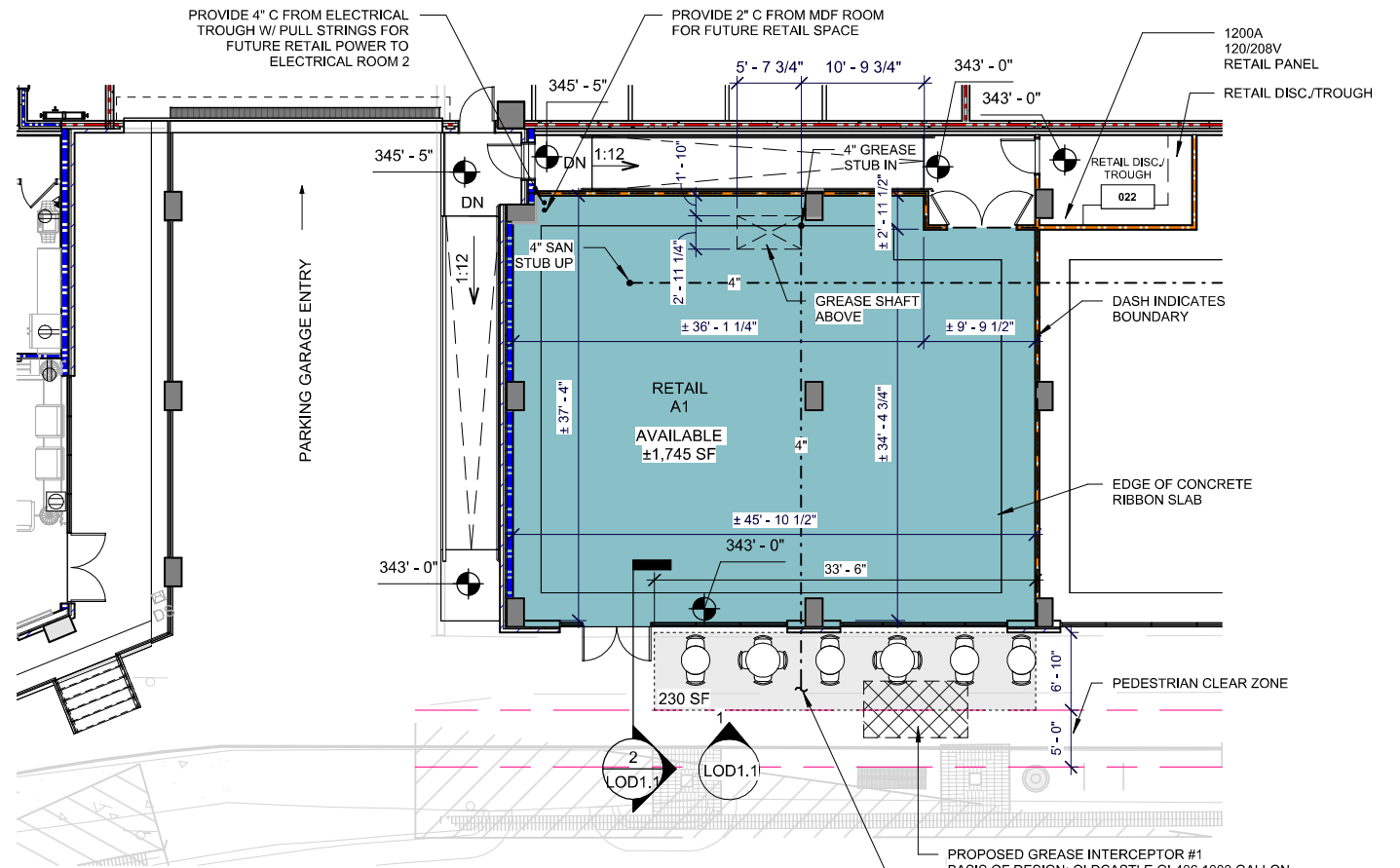

WYE APARTMENTS
 701 WASHINGTON ST., DURHAM, NC

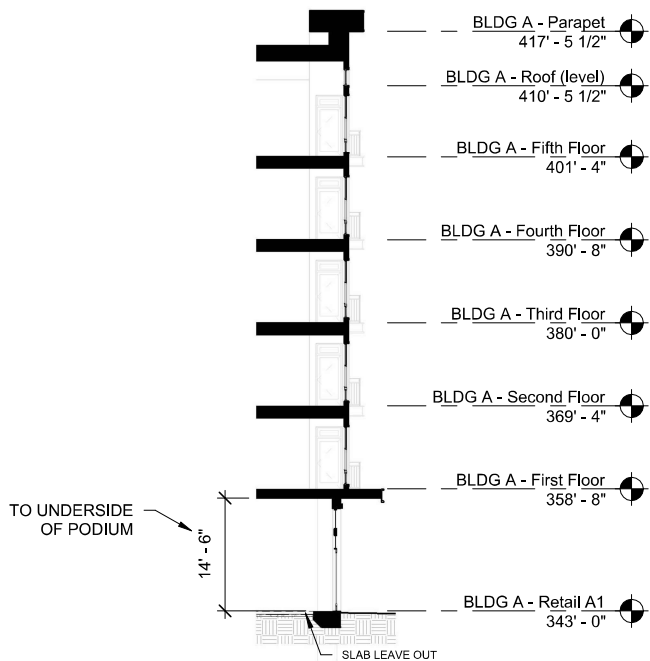

RETAIL A1 SECTION 2

1/16" = 1'-0"



RETAIL A1 ELEVATION 1

1/16" = 1'-0"

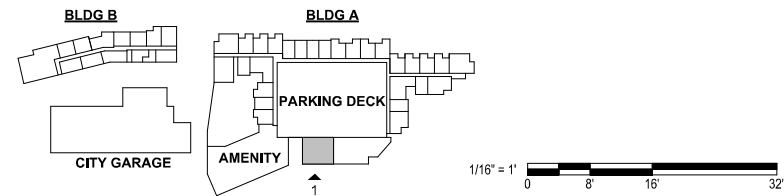

RETAIL A1 ELEVATION & SECTION
1/16" = 1'-0"

LOD1.1

220045 | 08.18.2023

© 2022 Cline Design Associates, PA. This graphic is for illustrative purposes only and is subject to change.



WYE APARTMENTS
701 WASHINGTON ST., DURHAM, NC

AREA OF DEMISED SPACE TAKEN FROM OUTSIDE FACE OF EXTERIOR WALLS, ESTIMATED CENTERLINE OF DEMISING WALLS, AND OUTSIDE FACE OF COMMON WALLS.

A2:

- CEILING HEIGHT = 16'-6"
- FRONTAGE = 114'-2"
- DEPTH = 34'-4"
- # OF ENTRANCES = 2 SETS OF DOUBLE DOORS
- GREASE TRAP = 1
- VENT CHASE = 5'-1/4" x 3'-10 3/4"
- OUTDOOR SPACE = 318 SF
- PLAZA = 2,143 SF

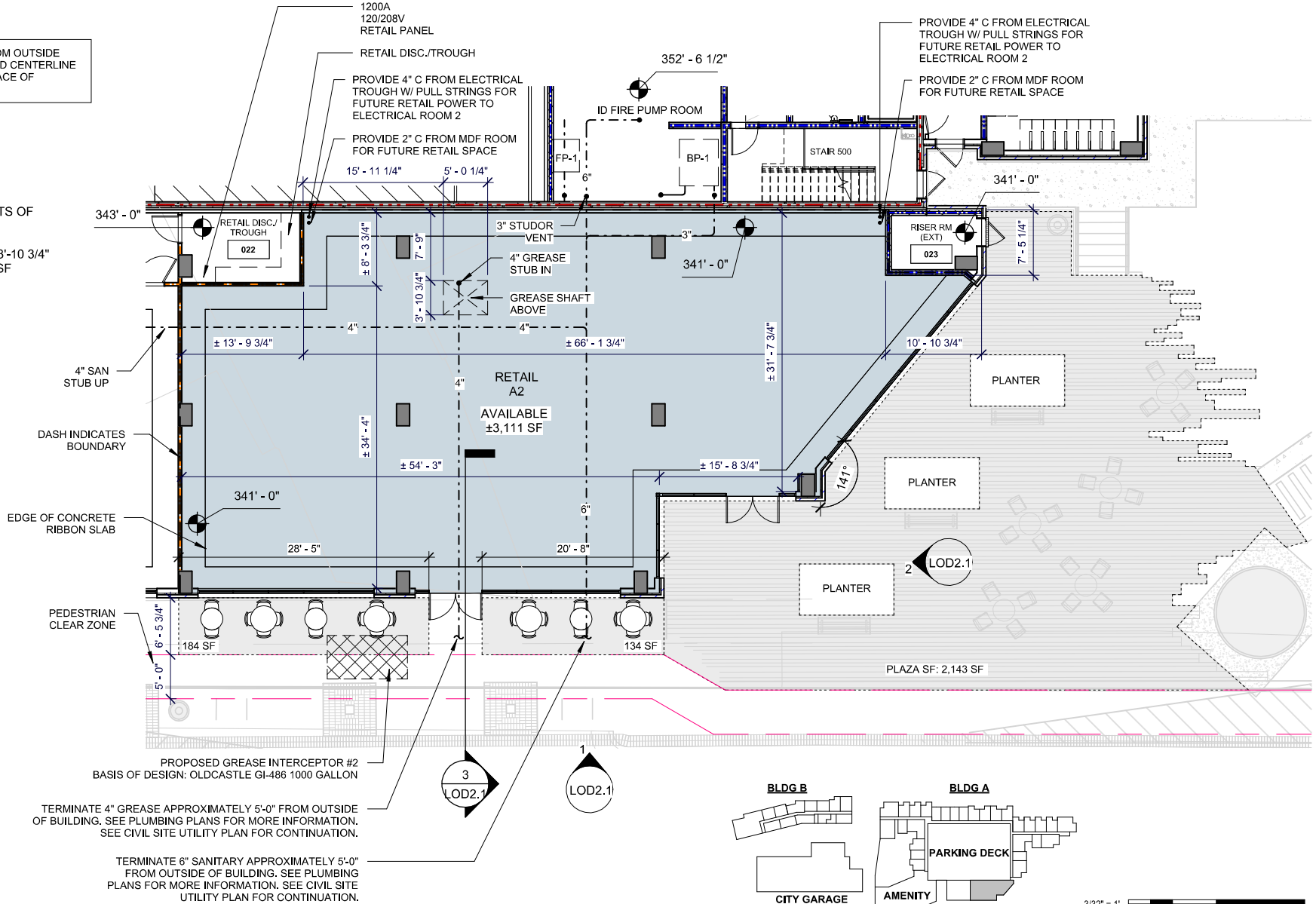

WYE APARTMENTS
701 WASHINGTON ST., DURHAM, NC

RETAIL A2 PLAN
3/32" = 1'-0"

220045 | 08.18.2023

© 2022 Cline Design Associates, PA. This graphic is for illustrative purposes only and is subject to change.

LOD2

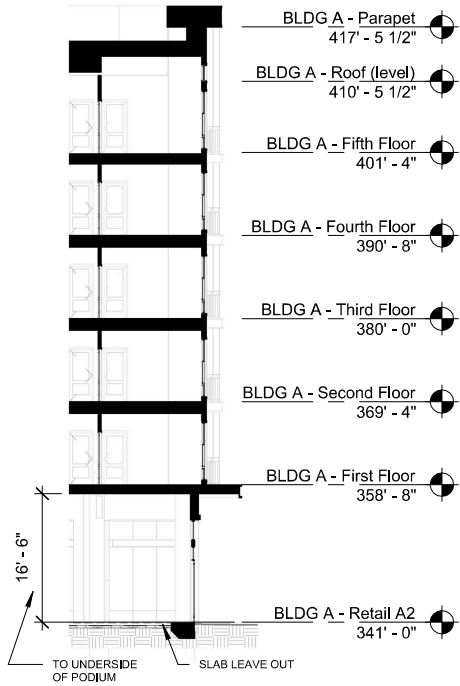

RETAIL A2 SECTION 3
1/16" = 1'-0"



RETAIL A2 ELEV 2 2
1/16" = 1'-0"



RETAIL A2 ELEV 1 1
1/16" = 1'-0"

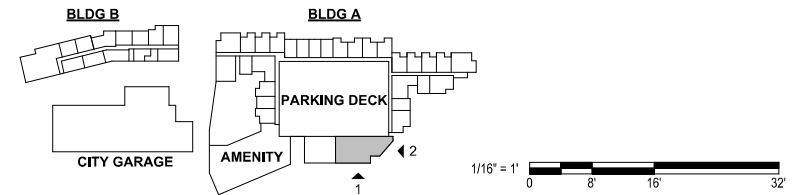

RETAIL A2 ELEVATIONS & SECTION
1/16" = 1'-0" 220045 | 08.18.2023
© 2022 Cline Design Associates, PA. This graphic is for illustrative purposes only and is subject to change.



WYE APARTMENTS
701 WASHINGTON ST., DURHAM, NC